

For +/-15V rails change R109 to 62K
 For +/-12V rails change R109 to 30K

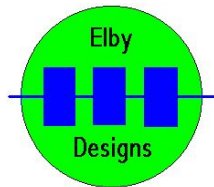
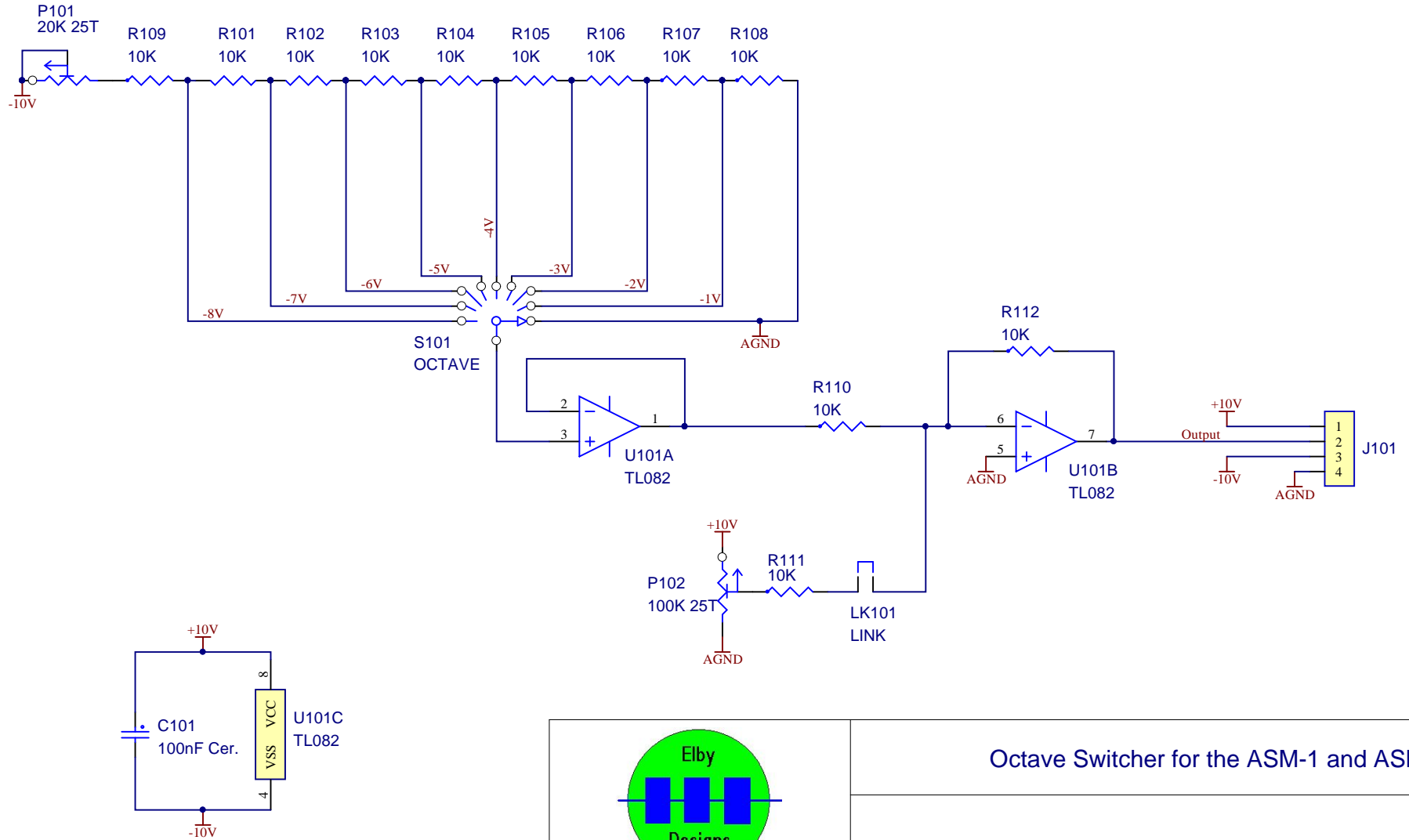

9 Follan Close
 Kariang
 NSW 2250
 Australia

Octave Switcher for the ASM-1 and ASM-2

Size A4	FCSM No. 2/04/2016	DWG No. octave.schdoc	Rev 2
Scale	Laurie Biddulph	Sheet 1 of 1	

1 2 3 4 5 6 7 8

A

A

B

B

C

C

D

D

E

E

F

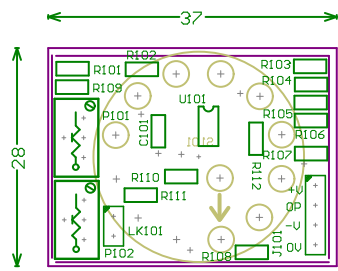

RoHS compliant - Immersion Gold over Immersion Silver

FR4, 1.6mm thick

Matt-Green solder-mask to 2 sides

Finished external copper weight 1oz

Elby Designs
 Kariong, NSW 2250
 Australia
www.elby-designs.com

Octave Switcher

All dimensions in millimeters unless stated otherwise.

(A4) Not to scale

Rev: 2

Date: 11/10/07

1 2 3 4