

Transformer Examples

WARNING - LETHAL VOLTAGES

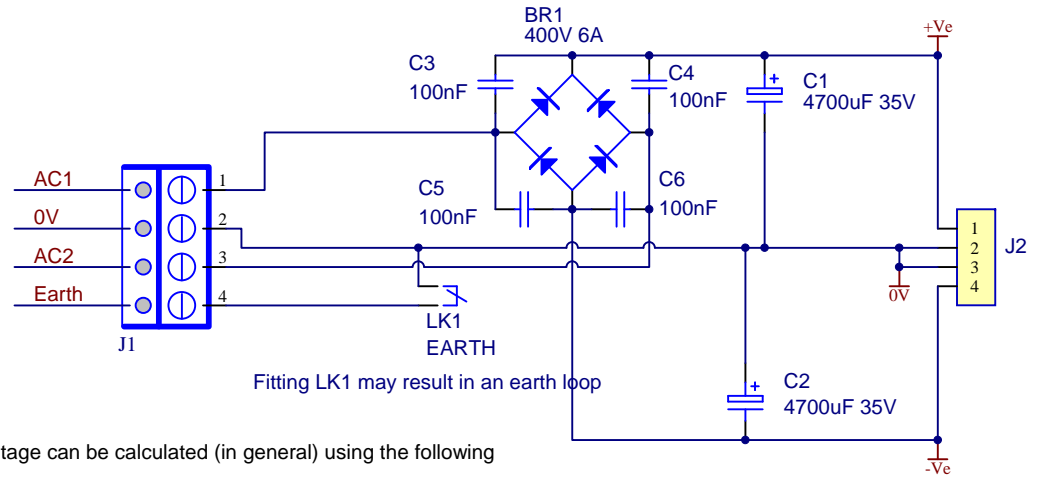
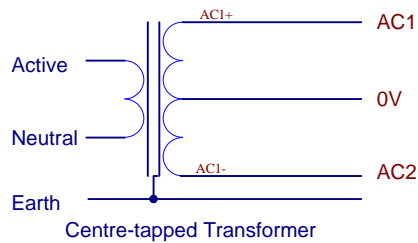
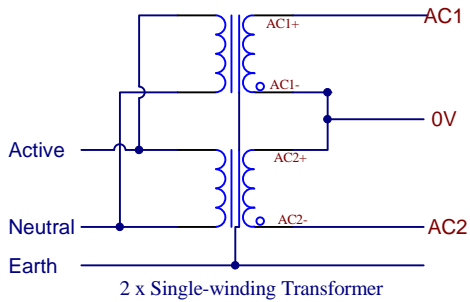
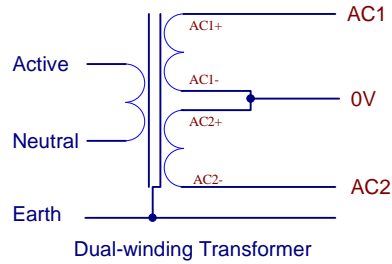

Transformer secondary voltage can be calculated (in general) using the following formula:-

$$V_{sec} = \frac{V_{out} + V_{reg} + (2 \times V_{diode}) + V_{ripple}}{0.92} \times 0.707 \times mf$$

where -

- V_{sec} = transformer output voltage
- V_{out} = regulator output voltage
- V_{reg} = voltage drop across regulator
- V_{diode} = voltage drop across the bridge/diodes
- V_{ripple} = typical ripple voltage across smoothing capacitors
- mf = mains factor = normal mains voltage / minimum mains voltage

Transformer secondary current can be calculated (in general) using the following formula:-

$$T_{cur} = 1.8 \times I_{cur}$$

where -

- T_{cur} = transformer output current
- I_{cur} = maximum current drawn by load

Example for a dual 15VDC @ 300mA supply as required by the ASM-2 on a 240VAC 50Hz supply

$$V_{sec} = \frac{15 + 3 + (2 \times 0.6) + 2}{0.92} \times 0.707 \times (240 / 220) = 17.77.2VAC \Rightarrow 18VAC$$

$$T_{cur} = 1.8 \times 0.3 = 0.54Amps$$

$$VA = (18 + 18) \times 0.54 = 19.44VA$$

Therefore the transformer should have 2 x 20VAC secondary outputs and be rated to 20VAC.

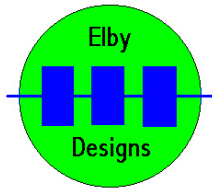

9 Follan Close
Kariong
NSW 2250
Australia

Power Supply Design
(uses Raw-DC unit)

Transformer Selection

Size A4	FCSM No. 26/12/2007	DWG No. psu-design.schdoc	Rev 2
Scale		Laurie Biddulph	Sheet 1 of 1