

Vbase is calculated as follows:-

$$V_{base} = \frac{V_{in} \cdot \text{Gain}}{(56K + 1K + 42R2)} \times (1K + 42R2) = 18.77\text{mV for a } 1\text{V input and unity gain}$$

The range afforded by P107 is (assuming 100K input resistor), thus,

P107	Gain	Vbase
0K (minimum)	0.931	17.0mV
10K (maximum)	1.031	18.8mV

This puts 18mV near the centre of the trim range.

CREDITS:

Terry Mikulic, "New Design Ideas for Voltage-Controlled Oscillators" Electronotes, Vol. 8, No. 62, Feb. 1976, pp 13-15

Bernie Hutchins, "The ENS-76 Home-Built Synthesizer System - Part 7, VCO Options" Electronotes, Vol. 9, No. 75, March 1977, pp 3-10

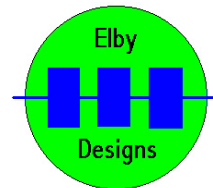
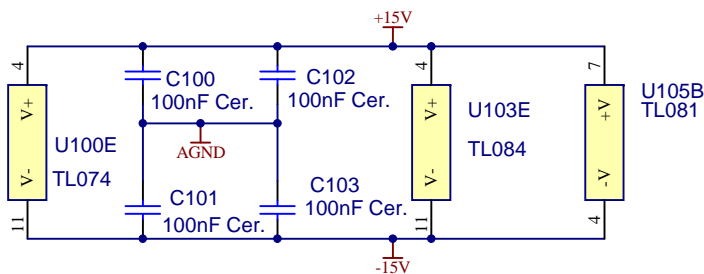
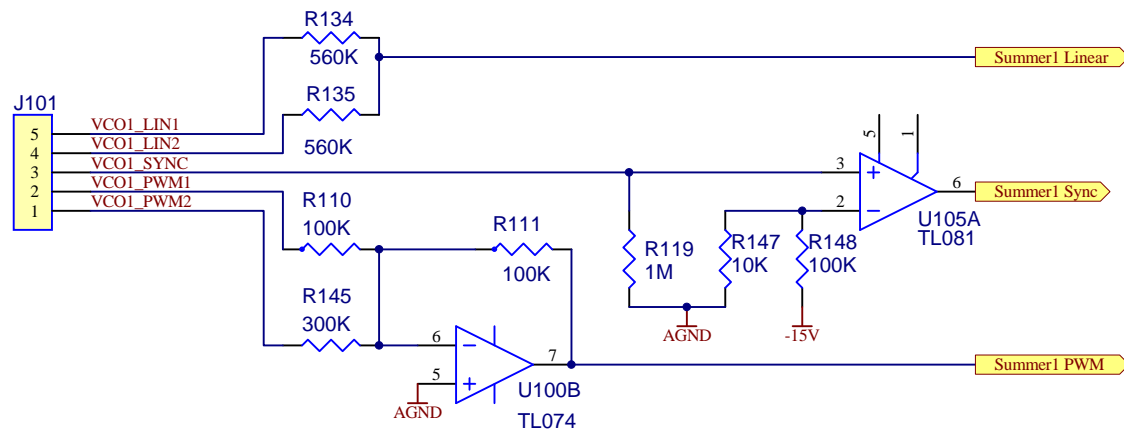

9 Follan Close
Kariiong
NSW 2250
Australia

ASM2 - Voltage Controlled Oscillator (1)

Summer

Size A4	FCSM No. 21/08/2010	DWG No. vco1-summer.schdoc	Rev C
Scale	Laurie Biddulph	Sheet 19 of 24	