

Cost reductions can be achieved by omitting the temperature oven components above. U804A should then be replaced with matched NPN transistors.

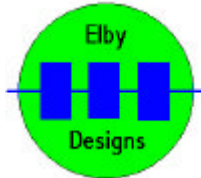
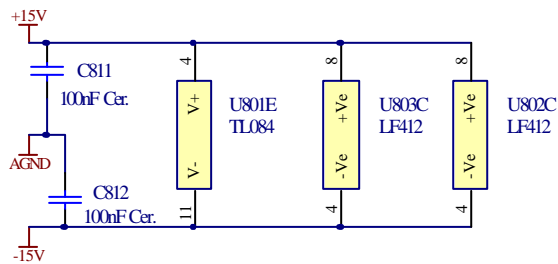

9 Follan Close
Karing
NSW 2250
Australia

ASM2 - Moog Voltage Controlled Ladder Filter

Oven & Poier Supply

Size A4	FCSM No. 23/04/2006	DWG No. vcf2-oven&psu.s15	Rev A
Scale	Laurie Biddulph	Sheet 15 of 24	