

S&H LED must be fitted for correct operation of the module

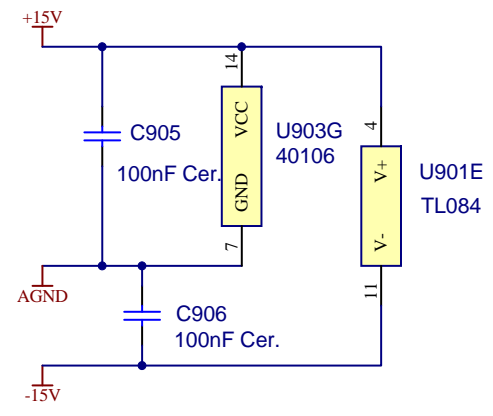

LFO has a range of approximately 0.5Hz to 600Hz.  
 S&H circuit measured to have 45uV/S droop  
 Acquisition time is typically 100uS

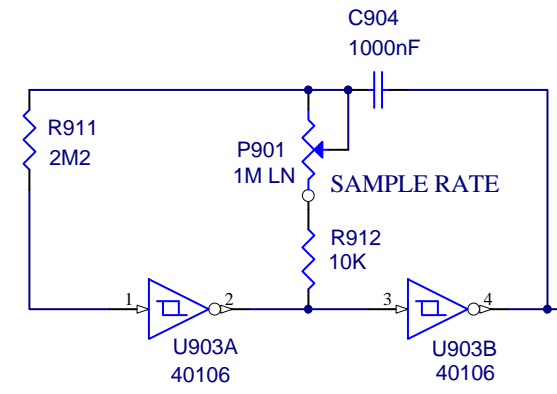
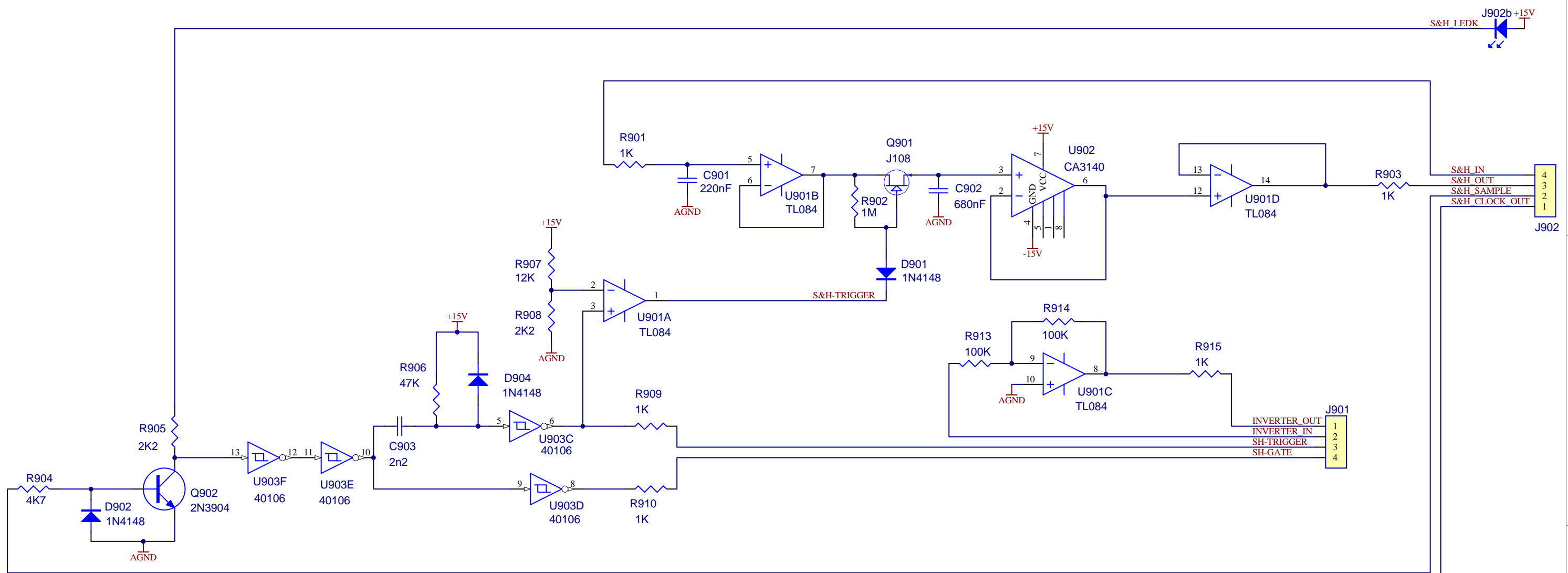
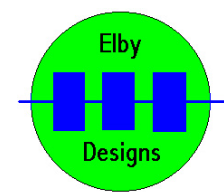

9 Follan Close  
 Kariong  
 NSW 2250  
 Australia

<b>ASM-2</b>			
<b>Sample &amp; Hold</b>			
Size A3	FCSM No. 21/08/2010	DWG No. s-h.schdoc	Rev A
Scale	Laurie Biddulph		Sheet 9 of 24